



ER655H

SDLG Compact Excavator
5.9 t (13,007 lbs) | 35.5 kW (48 hp)

● Highlights

- The ER655H is equipped with a Yanmar engine designed to work seamlessly with the hydraulic system, providing optimal break out force and lifting capacity.
- New generation ROPS cab providing a comfortable and spacious operating environment, as well as an excellent field of view improving the operating experience.
- Standard unit offers a 12V outlet, USB port, radio, Bluetooth, and hands-free phone.
- Auxiliary pipelines with 5 quick connectors, allow attachments to be changed quickly and efficiently.
- Easily accessed service points, wide-opening engine hood.



Reliability In Action

ER655H Specifications

Operating weight	kg (lbs)	5,900 (13,007)
Engine model	-	Yanmar 4TNV86CT
Rated power	kW (hp)	35.5 (48)
Rated engine speed	rpm	2,400
Displacement	ml (in ³)	2,091 (127.6)
Pump capacity	L/min (gal/min)	151.2 (39.9)
Main relief set pressure	bar (psi)	263 (3814.5)
Travel low speed	km/h (mi/h)	2.2 (1.4)
Travel high speed	km/h (mi/h)	4.4 (2.7)
Gradeability	°	30
Max. digging force of bucket	kN (lbf)	45 (10,116)
Max. digging force of arm	kN (lbf)	27.5 (6,182)
Swing speed	r/min	10
Blade (width * height)	mm (in)	380 (15") * 1,980 (78")
Ground pressure	kPa (psi)	33.4 (4.8)
Fuel tank	L (gal)	65 (17.2)

Dimensions

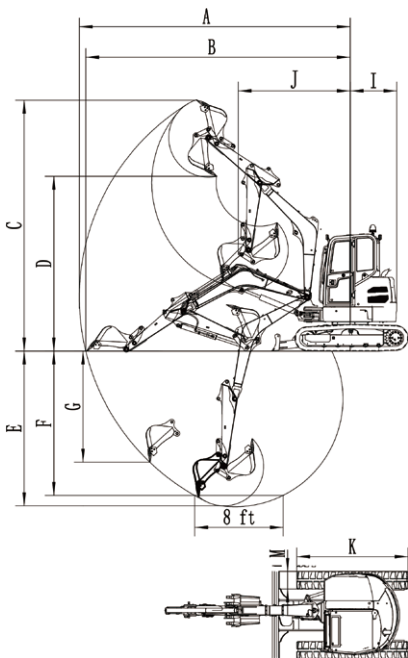

Boom length	mm (ft in)	2,800 (9' 2")
Arm length	mm (ft in)	1,540 (5' 0.6")
Bucket capacity	m ³ (yd ³)	0.18 (0.24)
Overall shipping size (L * W * H)	mm(ft in)	5,485 (18') * 1,980 (6' 6") * 2,545 (8' 4")
A Max. digging reach	mm (ft in)	6,043 (19' 10")
B Max. digging reach on ground	mm (ft in)	5,910 (19' 5")
C Max. cutting height	mm (ft in)	5,608 (18' 5")
D Max. dumping height	mm (ft in)	3,876 (12' 8")
E Max. digging depth	mm (ft in)	3,492 (11' 5")
F Max. digging depth (horizontal 8ft)	mm (ft in)	3,090 (10' 2")
G Max. vertical wall digging depth	mm (ft in)	2,633 (8' 8")
I Tail swing radius	mm (ft in)	1,090 (3' 7")
J Min. front swing radius	mm (ft in)	2,637 (8' 8")
K Undercarriage Length	mm (ft in)	2,500 (8' 2")
M Track width	mm (ft in)	400 (1' 4")

*SDLG reserves the right to change specifications and materials at any time without prior notification. Features of the machine in photos may include additional equipment. If you need more information and available options, please contact your local distributor or SDLG.



Congratulations SDLG for winning EFQM Global Excellence Award, one of the top three quality awards in the world.

Member of the VOLVO Group since 2006

SDLG is member of the Volvo Group and a leading international manufacturer of construction machinery, and the national-level high-tech company, with a wide network of dealerships and service workshops throughout the world.

SDLG Europe B.V.

Contacts: Budapest, Benczúr u. 11, 1068 Hungary
Website: www.sdlg-eu.com | Email: info@sdlg-eu.com
sales@sdlg-eu.com | +36 30 247 2606