



L902HEV

SDLG Electric Wheel Loader
2.5 t (5,512 lbs) | 24 kWh

● Highlights

- SDLG exclusive electronic control system is adopted, with reasonable performance matching, comfortable operation and high work efficiency.
- Equipped with 24kWh battery capacity for long work runtime and CCS2 charging port as standard, which can be used for DC fast charging and on-board AC chargers.
- SDLG Intelligent Temperature Management System to keep the working temperature at its optimum.
- Equipped with an electronic control single handle, the operation is simple and convenient, efficient and comfortable.
- Integrated keypad control, HCl; Battery level, power, etc. are displayed in real time.



Reliability In Action

L902HEv Specifications

Standard bucket capacity	m ³ (yd ³)	0.35 (0.46)
Rated load	kg (lbs)	600 (1,323)
Operating weight	kg (lbs)	2500 (5,512 lbs)
Battery type	-	LFP
Battery capacity	kWh	24
Voltage	V	358.4
Indicative runtime (depending on application)	h	4-6
Motor type	-	PMSM
Rated power	kW (hp)	17.2 (23)
Speed	km/h (mph)	0-20 (0~12.4)
Breakout force	kN (lbf)	17 (3,822)
Tire size	-	10-16.5

Dimensions

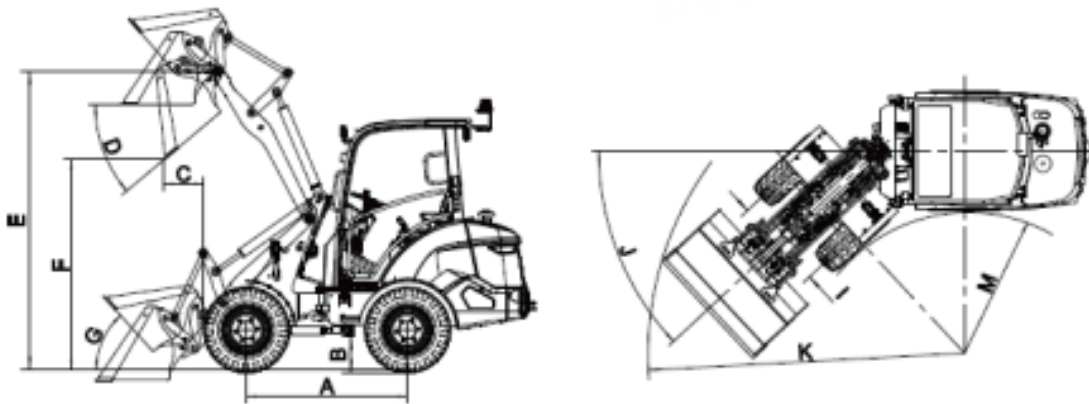

Overall shipping size (L * W * H)	mm (ft in)	4,410 (14' 5.6")×1,220 (4')×2,282 (7' 5.8")
A Wheelbase	mm (ft in)	1,470 (4' 9.9")
B Ground clearance	mm (ft in)	220 (8.6")
C Reach at max. height	mm (ft in)	365 (2.4")
D Dumping angle	°	45
E Height at bucket pin	mm (ft in)	2,728 (8' 11.4")
F Dumping height	mm (ft in)	1,910 (6' 3.2")
G Bucket rollback at ground level	°	47
I Wheel tread	mm (ft in)	820 (2' 8.3")
J Articulation angle	°	43
K Turning radius at over bucket	mm (ft in)	2934
M Turning radius at inside of tires	mm (ft in)	1340

*SDLG reserves the right to change specifications and materials at any time without prior notification. Features of the machine in photos may include additional equipment. If you need more information and available options, please contact your local distributor or SDLG.



Congratulations SDLG for winning EFQM Global Excellence Award, one of the top three quality awards in the world.

Member of the VOLVO Group since 2006

SDLG is member of the Volvo Group and a leading international manufacturer of construction machinery, and the national-level high-tech company, with a wide network of dealerships and service workshops throughout the world.

SDLG Europe B.V.

Contacts: Budapest, Benczúr u. 11, 1068 Hungary
Website: www.sdlg-eu.com | Email: info@sdlg-eu.com
sales@sdlg-eu.com | +36 30 247 2606